

Dome Supremacy®

PS-301N/P



.....	2		
.....	3	11
.....	4	12
.....	4	14
.....	5	15
.....	5	15
.....	6		
.....	7		
.....	8		
.....	8		
.....	10		
.....	10		
.....	10		



FCC

FCC:

15 FCC.

ICES-003.

CE



1.

2.

3.

4.

5.

6.

7.

8.

9.

10.

11.

12.

13.

14.

15.

16.

17.

A.

B.

C.

D.

E.

F.

18.

19.

20.

Dome Supremacy ®

0.1 °

Dome Supremacy

Dome Supremacy

Dome Supremacy

Dome Supremacy ®

30x

248

8

4

240

Dome Supremacy

30x

- ø125
- IP66 ()
- 1/4" IT Super HAD CCD 410,000
- 520 () / 570 ()
- 30x (f= 3.3 ~ 99)
- 0.008 (DSS, -)
- RS-485
- 8
- 380° ()
- PTZ-
- 248
- 8
- 4 ()
- 240
- ()
- 8 2
- RS-485
- 24 , 1.5 A.

SS1: 1- (ID)

S2: 10- (ID)

S3: 100- (ID)

) S3=1, S2=2, S1=8, ID -128

(1)

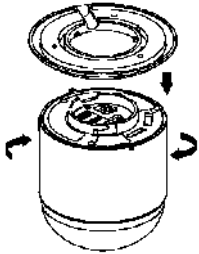

(4)

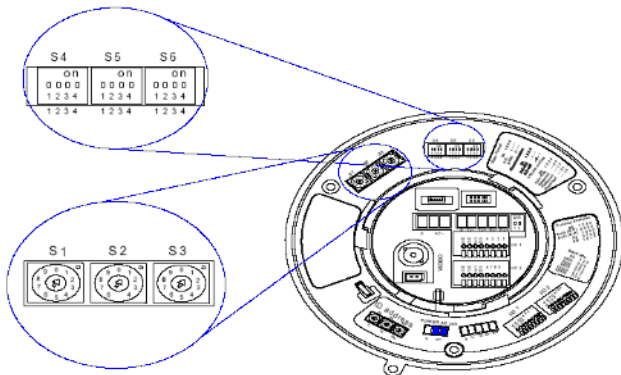
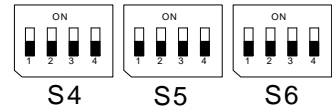

S4 :

S5 :

S6 :

S4		Video Format
1		
On		PAL
Off		NTSC

S4		Communication
2		
On		RS-422
Off		RS-485

S4		Camera module
3	4	
Off	Off	Auto detection
On	Off	Reserved
Off	On	X30 Camera
On	On	Reserved

S5				Protocol
1	2	3	4	
Off	Off	Off	Off	Auto detection (No Parity)
On	Off	Off	Off	Auto detection (Even Parity)
Off	On	Off	Off	Auto detection (Odd Parity)
On	On	Off	Off	Reserved
Off	Off	On	Off	HW
On	Off	On	Off	P-D
Off	On	On	Off	VCN
On	On	On	Off	SNM
Off	Off	Off	On	DNC
On	Off	Off	On	KTL
Off	On	Off	On	PS
On	On	Off	On	SAE
Off	Off	On	On	SAT
On	Off	On	On	VL
Off	On	On	On	DMD
On	On	On	On	HW factory default

(2)

1.2



1: ON ()/ 2: ON..

1: OFF()/2:OFF...

(3)

(ID)

(ID).

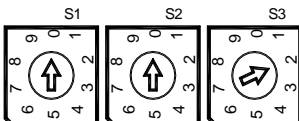

S6			Baud Rate
1	2	3	
Off	Off	Off	2400 bps
Off	Off	On	4800 bps
Off	On	Off	9600 bps
Off	On	On	19200 bps
On	Off	Off	38400 bps
On	Off	On	57600 bps
On	On	Off	115200 bps
On	On	On	230400 bps

S6		Extended ID
4		
On		0-999
Off		1000-3999

③

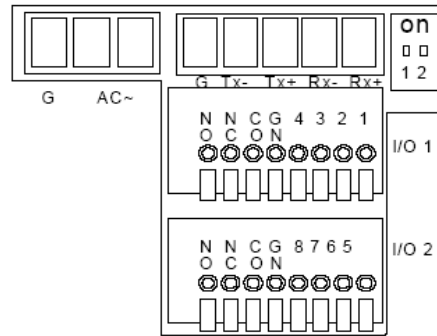

(2)

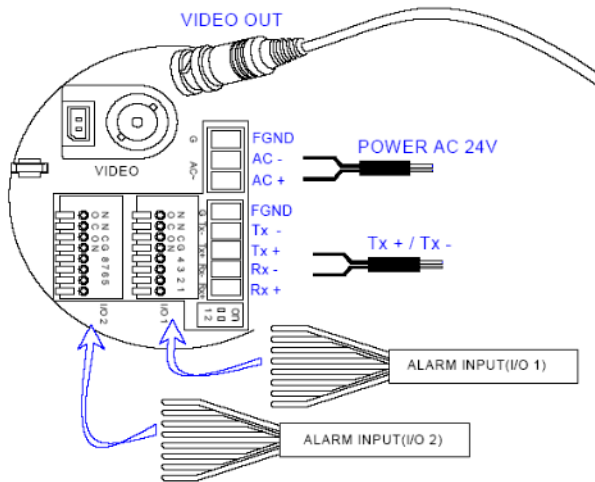

ALARM PIN DETAILS			
ALARM1		ALARM2	
1	NO A	1	NO B
2	NC A	2	NC B
3	COM A	3	COM B
4	GND	4	GND
5	ALARM4	5	ALARM8
6	ALARM3	6	ALARM7
7	ALARM2	7	ALARM6
8	ALARM1	8	ALARM5

④

24 , 1000 A

2

⑤

PTZ -
PTZ -
("OFF").

②

RS485, RS422, TX-, RX+(TX-), (RX+), (RX-)
DVR, RS422, RX+, RX-, TX+, TX+, TX-
(BNC)

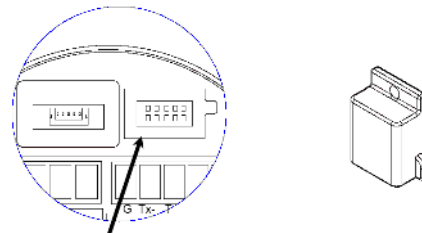

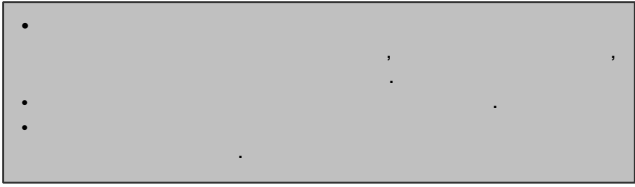

- ①
- ②
- ③
- ④

(1)

- ① (70)
- ②
- ③
- ④

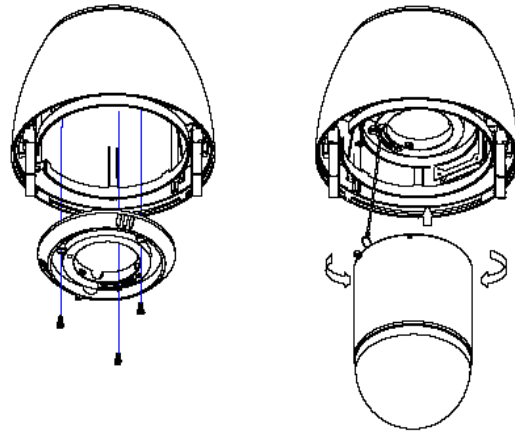
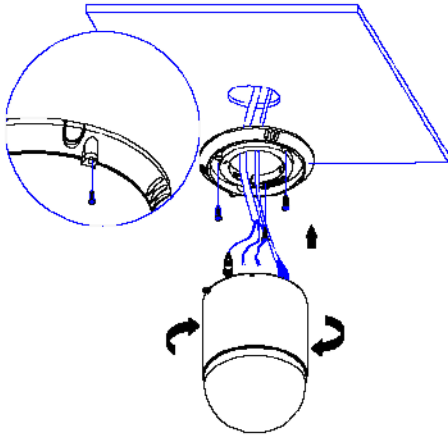

(4)

10

(24)

(2)

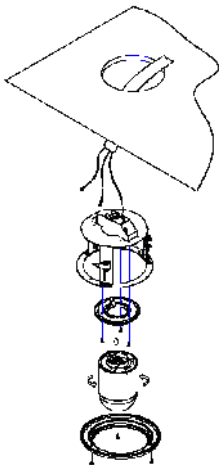

- ①
- ②
- ③
- ④

RAM TEST : PASS

SUPERMACY V1.0
 ID : 0001 9600BPS
 VAI T DOME SETT I NG
 PAN SENS I NG
 TI LT SENS I NG

SUPERMACY V1.0
 CAMERA TYPE : 480B
 ID : 0001 9600BPS
 WAIT DOME SETTING
 INT PAN OR GN SET OK
 INT TILT OR GN SET OK

“1” ,

“MENU”

3

No.95 +

Preset,

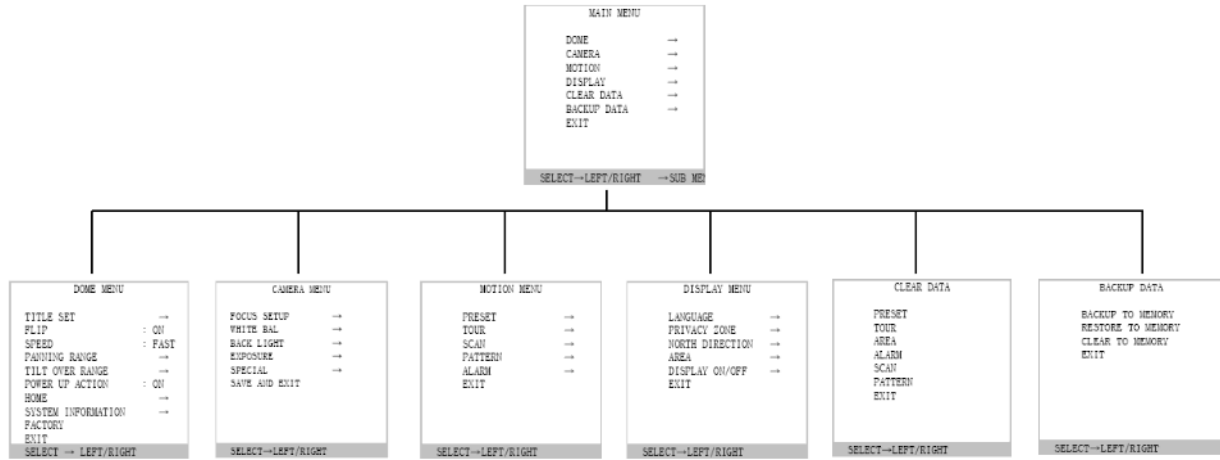

1

1.1

1.2 /

180°

1.3 /

1.8

1.4

1.9

**

1.5

2

1.6

2.1

AUTO:

1.7

MANUAL:

ONE PUSH: 5

MANUAL

ZOOM TRK: ON, OFF,

2.2

(WHITE BAL)

(°K).

ATW:

1,800~10,500K.

AWC:

AWC. Enter, AWC. Enter AWC

Red () Blue ()

* 2,000K, 3,200K 5,100K.

* Red:

* Blue:

2.3

WDR:

* WDR Limit: (WDR) High (), Middle () Low ()

() Shutter () Manual (), WDR

2.4

WDR, WDR. WDR WDR. WDR Limit (WDR),

*Auto:

*Manual:

*ESC:

*Anti-Flicker(): /

*Manual:

1/120,000

1/60

AGC:

AGC ()

SSNR:

SSNR

Off (), Low (), Middle () and High () () AGC "OFF" (), SSNR

2.5

D&N:

*COLOR: ()

*BW: (/)

*AUTO: ()

() AGC Auto () OFF

COLOUR () BW (-).

4.3

SYNC ():

4.4

: Internal Sync ()
Line Lock ().

8

AC Line Lock (),

4.5

- 0 360. 360°.

*Internal:

*Line Lock:

*Line Lock Phase:

0° 360° - 225°.

5

3

3.1

5.1

5.2

5.3

3.2

5.4

5.5

3.3

5.6

3.4

6

6.1

Preset (), Tour (), Pattern
()...

240

PTZ,

3.5

()

4

4.1

4.2

6.2

PTZ.

()

6.3

1 Dome Menu ()

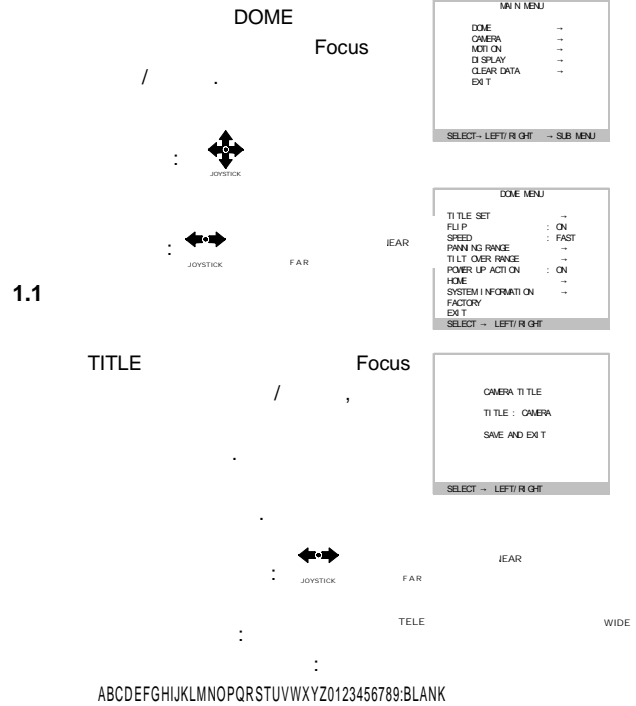

```

MINI MENU
DOME      --
CAMERA    --
MENU ON   --
DISPLAY   --
CLEAR DATA --
EXIT      --
SELECT -- LEFT/RIGHT -- SUB MENU
    
```

```

DOME MENU
TITLE SET --
FLIP       : ON
SPEED      : FAST
PANNING RANGE --
TILT OVER RANGE --
POWER UP ACTION : ON
HOME       --
SYSTEM INFORMATION --
FACTORY    --
EXIT      --
SELECT -- LEFT/RIGHT
    
```

```

CAMERA TITLE
TITLE : CAMERA
SAVE AND EXIT
SELECT -- LEFT/RIGHT
    
```

1.5

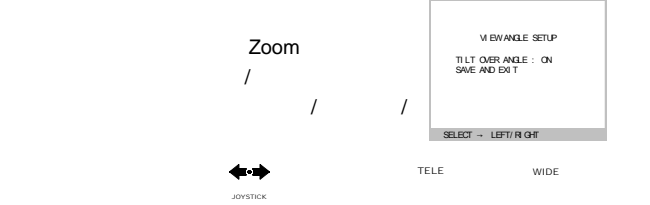

```

VIEW ANGLE SETUP
TILT OVER ANGLE : ON
SAVE AND EXIT
SELECT -- LEFT/RIGHT
    
```

1.6

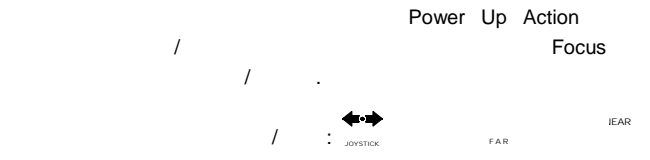

```

HOME FUNCTION
FUNCTION : TOUR
NUMBER   : ---
TIME    : 050 SEC
OPERATION : OFF
SAVE AND EXIT
SELECT -- LEFT/RIGHT
    
```

1.7

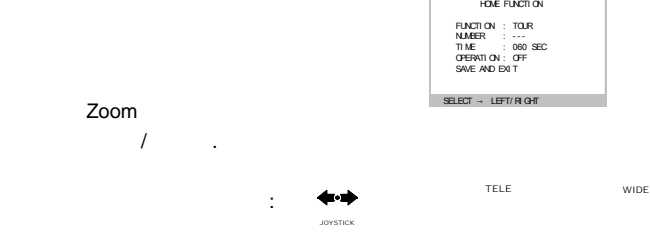

```

SYSTEM INFORMATION
CAMERA TYPE : 480B
FIRMWARE ON : V1.1
FIRMWARE ON : V1.0
PROTOCOL    : D
BALUN RATE  : 9600BPS
EXIT        --
SELECT -- LEFT/RIGHT
    
```

1.8

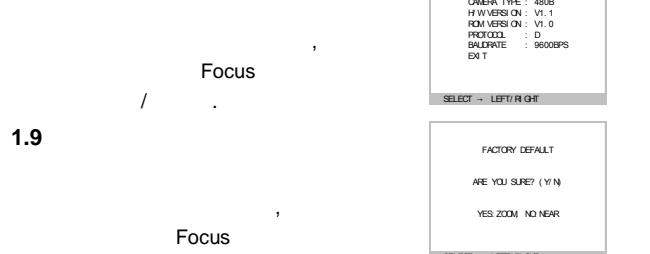

1.9

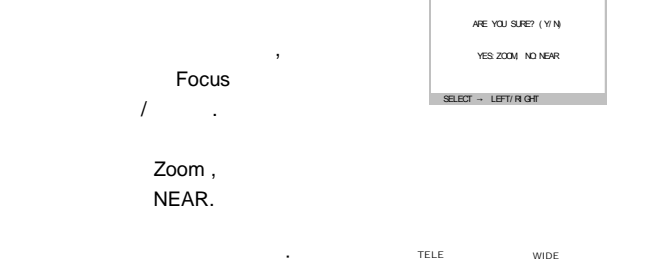

```

FACTORY DEFAULT
ARE YOU SURE? (Y/N)
YES ZOOM NO NEAR
SELECT -- LEFT/RIGHT
    
```

2

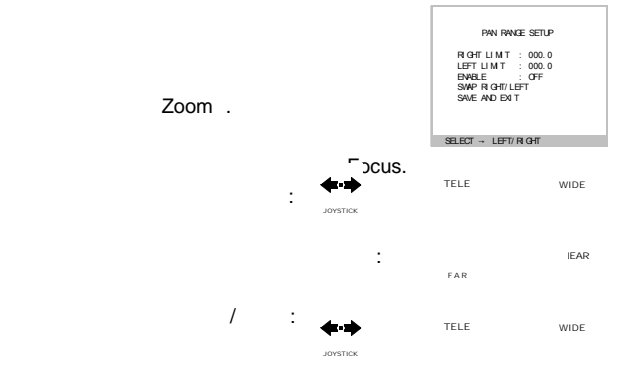

```

PAN RANGE SETUP
RIGHT LIMIT : 000.0
LEFT LIMIT  : 000.0
ENABLE      : OFF
SWAP RIGHT/LEFT
SAVE AND EXIT
SELECT -- LEFT/RIGHT
    
```

```

CAMERA MENU
FOCUS SETUP --
WHITE BAL --
BACK LIGHT --
EXPOSURE --
SPECIAL --
SAVE AND EXIT --
SELECT -- LEFT/RIGHT
    
```

```

FOCUS SETUP
MODE : AUTO
ZOOM TRK MODE : LOW
ZOOM TRK SPD : LOW
EXIT
SELECT -- LEFT/RIGHT/TELE/WIDE
    
```

2.2



TELE

WIDE

```

WB.
WH TE BAL
MODE      : ATW
COLOR TEMP : NI A
RED       : NI A
BLUE     : NI A
EXIT     :
SELECT - LEFT/RIGHT/TELE/WIDE

```

Zoom

2.3



TELE

WIDE

Back

```

Back
BACK LI GHT
MODE      : OFF
WDR LI M T : NI A
EXIT     :
SELECT - LEFT/RIGHT/TELE/WIDE

```

Light

(Off/WDR)

Zoom

2.4



TELE

WIDE

```

EXPOSURE
BRI GH NESS : 015
I R S       :
SHUTTER     :
ACC         :
SMNR        :
EXIT       :
SELECT - LEFT/RIGHT/TELE/WIDE

```

Zoom

3.3



TELE

WIDE

:

:

:

:

:

:

:

:

:

:

:

:

:

:

:

:

:

:

:

:

:

:

:

:

:

:

:

:

:

:

:

:

:

:

:

:

:

:

:

:

Scan

```

SCAN MENU
SCAN NO : 01      UNDERLINE
LABEL   : AUTOSCAN 01
START   : NONE
END     : NONE
SPEED   : 3
DIR     : CCW
SWAP    : OFF
CLEAR   :
SAVE AND EXIT :
SELECT - LEFT/RIGHT

```

Scan.

Scan

Zoom

2.5



TELE

WIDE

```

SPECIAL SETUP
DAY/NIGHT : COLOR
SYNC      :
EXIT     :
SELECT - LEFT/RIGHT/TELE/WIDE

```

Special.

Zoom

3.4



TELE

WIDE

```

PATTERN MENU
PATTERN NO : 01      UNDERLINE
LABEL      : PATTERN 01
RECORD SAVE : 000 SEC
PLAY       :
CLEAR     :
SAVE AND EXIT :
SELECT - LEFT/RIGHT

```

Pattern

Pattern.

Pattern

Zoom

```

ALARM MENU
ALARM NO 001 : UNDERLINE
MOTION      : OFF
PRIORITY    : 3
ALARM IN    : OFF
ALARM QUIT  : OFF
HOLD        : 001 SEC
LATCH       : OFF
SAVE AND EXIT :
SELECT - LEFT/RIGHT

```

3

3.1

```

MONI ON MENU
PRESET --
TOUR   --
SCAN   --
PATTERN --
ALARM  --
EXIT   --
SELECT - LEFT/RIGHT

```

Preset

Zoom

3.5

```

PRESET MENU
PRESET NO : 001      UNDERLINE
LABEL     : PRESET
POSITION  : NONE
FOCUS     : AUTO
I R S     : AUTO
BLG       : OFF
CLEAR     :
SAVE AND EXIT :
SELECT - LEFT/RIGHT

```

Alarm

```

ALARM MENU
ALARM NO 001 : UNDERLINE
MOTION      : OFF
PRIORITY    : 3
ALARM IN    : OFF
ALARM QUIT  : OFF
HOLD        : 001 SEC
LATCH       : OFF
SAVE AND EXIT :
SELECT - LEFT/RIGHT

```

3.2



TELE

WIDE

Tour,

```

TOUR MENU
TOUR 01 : TOUR 01
LABEL   : TOUR 01
TOUR EDIT :
CLEAR   :
SAVE AND EXIT :
SELECT - LEFT/RIGHT

```

Zoom

Alarm

Alarm.

4.
4.1

Language
/ ()
Language

JOYSTICK TELE WIDE

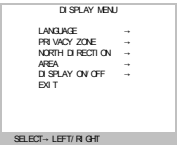

Language

/

JOYSTICK



4.2

Privacy zone

Privacy zone.

Zoom,

Focus.

JOYSTICK TELE WIDE

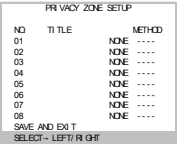

IEAR

4.3

North direction

Zoom,
Focus.

JOYSTICK TELE WIDE

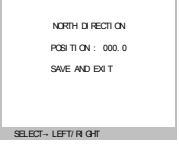

IEAR

4.4

Area
/ Area

JOYSTICK TELE WIDE

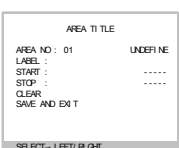

Zoom

JOYSTICK

4.5

5

Alarm, Scan / Preset, Tour, Area, Pattern

Display On/Off /

On/Off.

Display On/Off
Zoom

Display

JOYSTICK

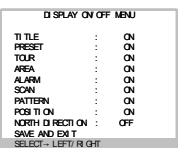

JOYSTICK

TELE WIDE

IEAR

6

PTZ

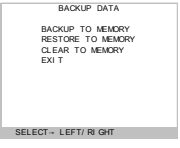

Backup Data.

JOYSTICK

TELE WIDE

24 . 60 / 24 . 50
 ()
 18.0 (1.0 A Max.)
 30 ()



() 21 - 28 . , 50/60 - 15

360° , 0.1° , 90°/
 (64)

() 21 - 28 . , 50/60 - 30

380°/ , ± 0.10°
 0.1° , 90°/ . ()

RS-422, 485

+ / -
 BNC

150°/ , ± 0.05°
 : . 1.6

8 N/O N/C
 2 :

2A @30VAC

125(Ø) x 194() - 4.9"(Ø) x 7.64" (D)

10-

()

CE EMC , FCC

A

IP66 ()

1/4" - Sony

0°C 50°C
 -40°C 50°C
 -20°C 60°C
 0% 90% ()
 -30°C , 40°C
 5°C , 15°C

(x) 811 x 508 (NTSC), 795 x 596 (PAL)
 768 x 494 (NTSC), 752 x 582 (PAL)
 /

1.0V p-p, 75 , BNC

248 , 0.1°

8

4

240

50 (AGC)

(180°)

520 . () / 570 (- .)

8 (/)

0.4 () , 0.08 (/) / (@50IRE),
 0.003 (/) /
 @50IRE)

999 ID ()

RS-485 / RS-422

/ (1/60 - 1/120.000)

()
 2400, 4800, 9600, 19200 /

8 (NO/NC,)

WDR

(x2 - x128) /
 ICR() /

2 ()

52 /
 ATW (: /)

16

AWC/ (1,800K - 10,500K)
 1/100
 (1/120)

(N,S,W,E) (/)

(8 .)

OSD

(/) /

F3.3 ~ 99.0mm (30X
)

1:1.6 . 1:3.7
F=3.3 58°(.) X 44.8°(.)
f=99.0 2.22°(.) X 1.68°(.)
1.2 ()

: , 2X, 4X, 8X (

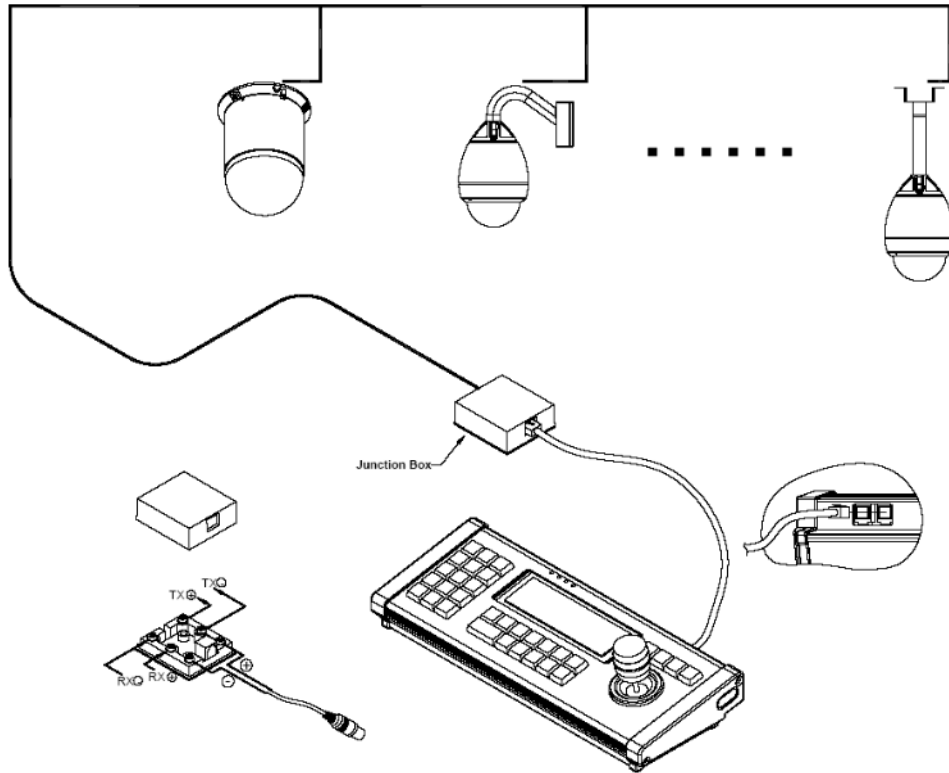

PRESET FUNCTION ().
PRESET FUNCTION

FUNCTION	KEY	Preset No.	How To.	EXAMPLE
PRESET	PRESET	1-59	No.+ Preset	1+PRESET
SCAN	PRESET	61-68	No.+ Preset	61+PRESET
TOUR	PRESET	71-78	No.+ Preset	71+PRESET
PATTERN	PRESET	81-84	No.+ Preset	84+PRESET
AUTOSCAN MENU	PRESET	60	No.+ Preset	60+PRESET
TOUR MENU	PRESET	70	No.+ Preset	70+PRESET
PATTERN MENU	PRESET	80	No.+ Preset	80+PRESET
ALARM RESET	PRESET	90	No.+ Preset	90+PRESET
RUN HOME	PRESET	91	No.+ Preset	91+PRESET
AUTOPAN	PRESET	92	No.+ Preset	92+PRESET
ENTER	PRESET	94	No.+ Preset	94+PRESET
DOME MENU	PRESET	95	No.+ Preset	95+PRESET
ESC KEY	PRESET	96	No.+ Preset	96+PRESET
CTRL_KEY(In Menu)	PRESET	95	No.+ Preset	95+PRESET
Relay On	PRESET	85-88	No.+ Preset	
Relay Off	PRESET	69,79,89,99	No.+ Preset	

Dome Supremacy[®]

4F/403, - **193**, - , - , - , - ,
.: +82-32-676-0168 , : +82-32-681-7880
: www.dome-supremacy.com E-mail : sales@goodome.com